

1703

Hospitality Base Cabinet; Three Drawers

Cabinet de Bas Hospitalité; Trois Tiroirs
Gabinete Base para Hostelería; Tres Cajones

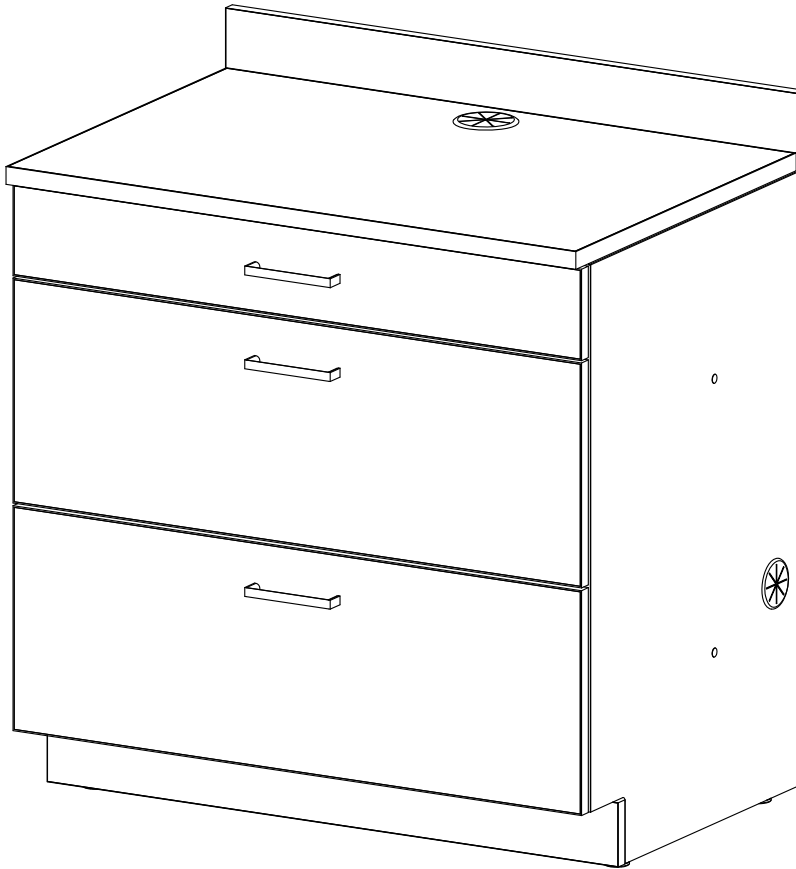

⚠ KEEP OUT OF REACH OF CHILDREN UNTIL ASSEMBLY IS COMPLETE, DUE TO THE PRESENCE OF SMALL OR SHARP PARTS.
ADULT ASSEMBLY REQUIRED

⚠ TENIR HORS DE PORTÉE DES ENFANTS JUSQU'À CE QUE
L'ASSEMBLAGE SOIT TERMINÉ, EN RAISON DE LA
PRÉSENCE DE PIÈCES PETITES OU TRANCHANTES.
ASSEMBLAGE ADULTE REQUIS

⚠ MANTENER FUERA DEL ALCANCE DE LOS NIÑOS HASTA QUE SE
COMPLETE EL MONTAJE, DEBIDO A LA
PRESENCIA DE PIEZAS PEQUEÑAS O AFILADAS.
SE REQUIERE MONTAJE DE ADULTOS

PRODUCT WARRANTY is available online at: **www.safcoproducts.com**

• LA GARANTIE DU PRODUIT est
disponible sur l'Internet : **www.safcoproducts.com**

• LA GARANTÍA DEL PRODUCTO está
disponible en la Internet: **www.safcoproducts.com**

For questions or concerns, please call **1-888-971-6225**
available Monday-Friday 7:30 AM to 5:00 PM (Central Time) (English-speaking operators)

Si vous avez des questions pour poser ou les préoccupations
pour exprimer, connecter au **1-888-971-6225**
de 7H30 à 17H00 (Heure centrale) (Opérateurs de langue anglaise)

Si usted tiene preguntas o preocupaciones,
por favor llame **1-888-971-6225**
de 7:30 AM a 5:00 PM (Hora Central) (Operadores que hablan inglés)

TOOLS REQUIRED: Phillips Screwdriver, Flathead Screwdriver, and Rubber Mallet
OUTILS REQUIS : Tournevis cruciforme, Tournevis à Tête Plate, et Maillet en Caoutchouc
HERRAMIENTAS REQUERIDAS: Destornillador Phillips, Destornillador de Cabeza Plana, y Mazo de Goma



PARTS LIST / LISTE DES PIÈCES / LISTA DE PIEZAS			
CODE / CODIGO	DESCRIPTION / DESCRIPTION / DESCRIPCIÓN	QTY. / QUANTITÉ / CANTIDAD	PART NO. / N° DE PIECE / NO. DE PIEZA
(A)	Top Panel / <i>Panneau Supérieur</i> / Panel Superior	1	44000004\$
(B)	Bottom Panel / <i>Panneau Du Bas</i> / Panel Inferior	1	41000019\$
(C)	Left Side Panel / <i>Panneau Latéral Gauche</i> / Panel Lateral Izquierdo	1	420000288\$
(D)	Right Side Panel / <i>Panneau Latéral Droit</i> / Panel Lateral Derecho	1	420000289\$
(E)	Lower Back Panel / <i>Panneau Arrière Inférieur</i> / Panel Trasero Inferior	1	410000017\$
(F)	Upper Back Panel / <i>Panneau Arrière Supérieur</i> / Panel Trasero Superior	1	410000018\$
(G)	Toe Kick Panel / <i>Panneau Coup de Pied D'orteil</i> / Panel de Patada del Dedo del Pie	1	420000015\$
(H)	Cross Support Panel / <i>Panneau de Support Croisé</i> / Panel de Soporte Cruzado	1	410000021\$
(I)	Backsplash Panel / <i>Panneau de Dosseret</i> / Panel de Protector Contra Salpicaduras	1	440000006\$
(J)	Small Drawer Outer Panel / <i>Panneau Extérieur de Petit Tiroir</i> / Panel Exterior del Cajón Pequeño	1	435000005\$
(K)	Small Drawer Inner Panel / <i>Panneau Intérieur de Petit Tiroir</i> / Panel Interior del Cajón Pequeño	1	435000009\$
(L)	Small Drawer Left Panel / <i>Panneau Gauche de Petit Tiroir</i> / Panel Izquierdo del Cajón Pequeño	1	435000007\$
(M)	Small Drawer Right Panel / <i>Panneau Droit de Petit Tiroir</i> / Panel Derecho del Cajón Pequeño	1	435000006\$
(N)	Small Drawer Back Panel / <i>Panneau Arrière de Petit Tiroir</i> / Panel Trasero del Cajón Pequeño	1	435000008\$
(O)	Large Drawer Outer Panel / <i>Grand Panneau Extérieur de Tiroir</i> / Panel Exterior del Cajón Grande	2	435000010\$
(P)	Large Drawer Inner Panel / <i>Grand Panneau Intérieur de Tiroir</i> / Panel Interior del Cajón Grande	2	435000014\$
(Q)	Large Drawer Left Panel / <i>Panneau Gauche de Grand Tiroir</i> / Panel Izquierdo del Cajón Grande	2	435000012\$
(R)	Large Drawer Right Panel / <i>Panneau Droit de Grand Tiroir</i> / Panel Derecho del Cajón Grande	2	435000011\$
(S)	Large Drawer Back Panel / <i>Panneau Arrière de Grand Tiroir</i> / Panel Trasero del Cajón Grande	2	435000013\$
(T)	Drawer Bottom Panel / <i>Panneau Inférieur du Tiroir</i> / Panel Inferior del Cajón	3	435000015\$

§Note: When corresponding about parts, be sure to state color: Asian Night/Black (AN), Mahogany (MH), Vanilla Stix (VS).

§Noter: Quand correspondre au sujet de parties, soyez sûr d'affirmer la couleur: Nuit Asiatique/Noir (AN), Acajou (MH), Vanille Stix (VS).

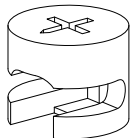
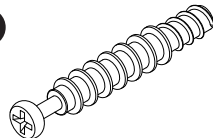
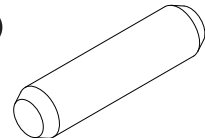
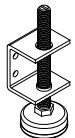
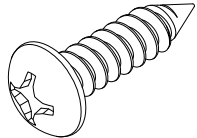
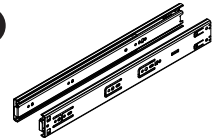
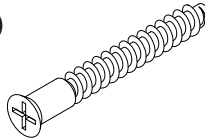
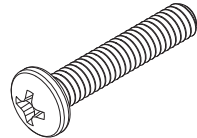
§Note: Al corresponder sobre las piezas, esté seguro declarar el color: Noche asiática/Negro (AN), Caoba (MH), Stix de Vainilla (VS).

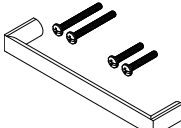
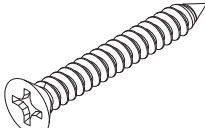
Hardware Pack / Paquet Matériel / Paquete Material: 900000351			
<p>U</p>  <p>Cam 15mm X 12.3mm <i>Came 15mm X 12.3mm</i> Leva 15mm X 12.3mm</p> <p>Qty. / Qté. / Cant. 18 920000310</p>	<p>V</p>  <p>Cam Post 44.5mm <i>Poteau de Came 44.5mm</i> Poste de Leva 44.5mm</p> <p>Qty. / Qté. / Cant. 18 920000504</p>	<p>W</p>  <p>Wood Dowel 8mm X 30mm <i>Cheville en Bois 8mm X 30mm</i> Pasador de Madera 8mm X 30mm</p> <p>Qty. / Qté. / Cant. 22 92000309</p>	<p>X</p>  <p>Leveler Assembly <i>Assemblage du Niveleur</i> Ensamblaje del Nivelador</p> <p>Qty. / Qté. / Cant. 4 960000004</p>
<p>Y</p>  <p>Screw #8 X 1/2" <i>Vis #8 X 1/2"</i> Tornillo #8 X 1/2"</p> <p>Qty. / Qté. / Cant. 52 905000470</p>	<p>Z</p>  <p>Drawer Slide Pack <i>Pack de Glissières de Tiroir</i> Paquete de Diapositiva de Cajón</p> <p>Qty. / Qté. / Cant. 3 920000534</p>	<p>AA</p>  <p>Screw 5mm X 40mm <i>Vis 5mm X 40mm</i> Tornillo 5mm X 40mm</p> <p>Qty. / Qté. / Cant. 40 905000439</p>	<p>BB</p>  <p>Screw 1/4"-20 X 1" <i>Vis 1/4"-20 X 1"</i> Tornillo 1/4"-20 X 1"</p> <p>Qty. / Qté. / Cant. 10 905000469</p>

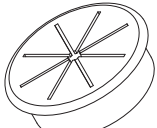
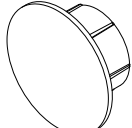
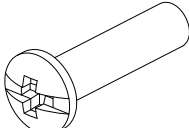
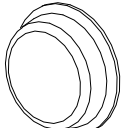
<p>CC</p>  <p>Handle & Screws #8-32 X 1" & 1 1/2" <i>Poignée avec Vis #8-32 X 1" & 1 1/2"</i> <i>Mango con Tornillos #8-32 X 1 1/2"</i></p> <p>Qty. / Qté. / Cant. 3 925000001</p>	<p>DD</p>  <p>Screw #8 X 1 1/4" <i>Vis #8 X 1 1/4"</i> <i>Tornillo #8 X 1 1/4"</i></p> <p>Qty. / Qté. / Cant. 2 905000060</p>	<p>EE</p>  <p>Grommet 80mm <i>Oeillet 80mm</i> <i>Ojal 80mm</i></p> <p>Qty. / Qté. / Cant. 1 920000057</p>	<p>FF</p>  <p>Grommet 60mm <i>Oeillet 60mm</i> <i>Ojal 60mm</i></p> <p>Qty. / Qté. / Cant. 2 920000056</p>
<p>GG</p>  <p>Hole Plug <i>Bouchon de Trou</i> <i>Tapón de Agujero</i></p> <p>Qty. / Qté. / Cant. 4 920000550</p>	<p>HH</p>  <p>Binding Barrel 1/4"-20 X 1 1/4" <i>Baril de Reiliure 1/4"-20 X 1 1/4"</i> <i>Barril de Unión 1/4"-20 X 1 1/4"</i></p> <p>Qty. / Qté. / Cant. 2 905000477</p>	<p>II</p> <p>Screw 1/4"-20 X 1/2" <i>Vis 1/4"-20 X 1/2"</i> <i>Tornillo 1/4"-20 X 1/2"</i></p> <p>Qty. / Qté. / Cant. 2 7005</p>	<p>JJ</p>  <p>Bumper <i>Pare-chocs</i> <i>Parachoque</i></p> <p>Qty. / Qté. / Cant. 6 920000434</p>

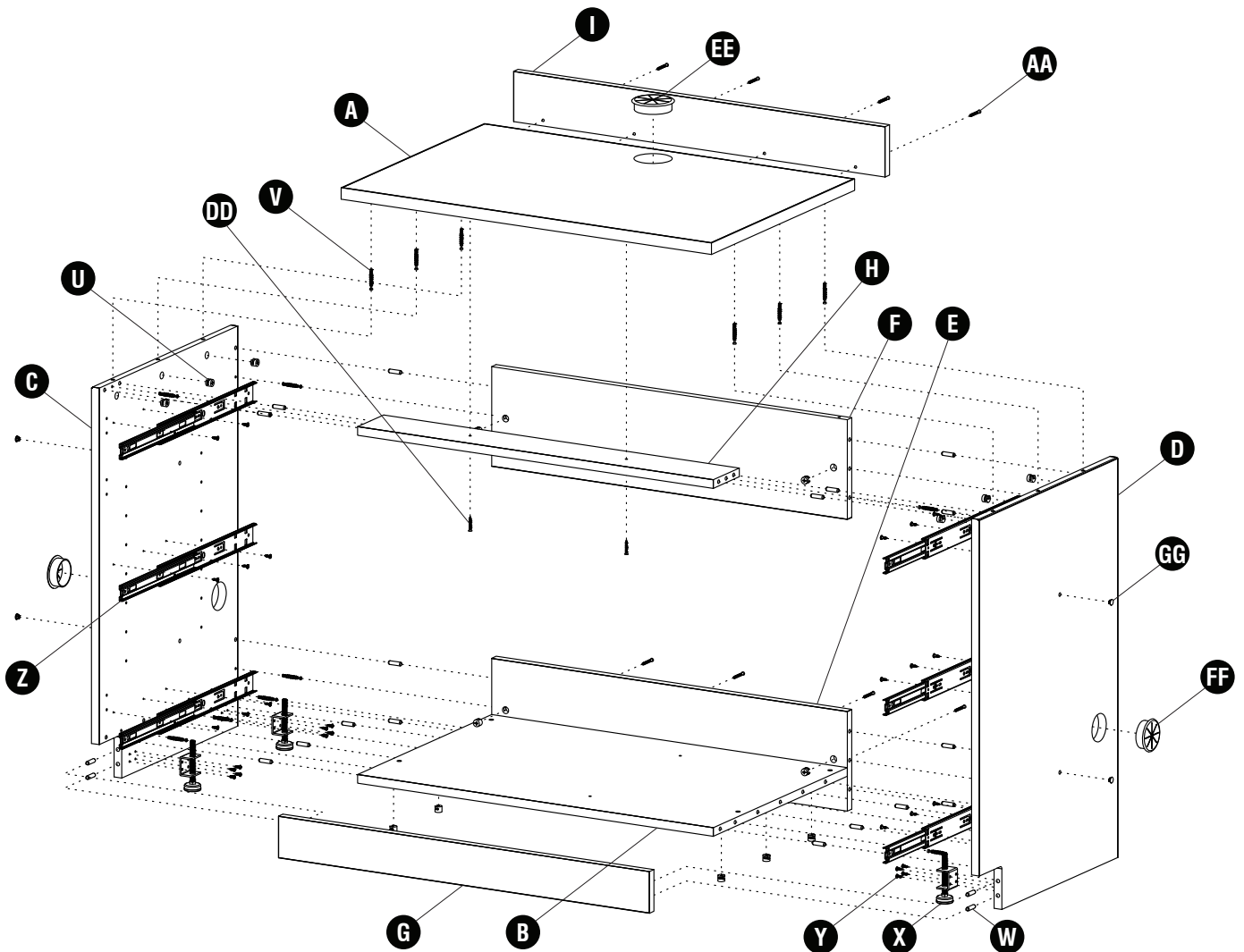

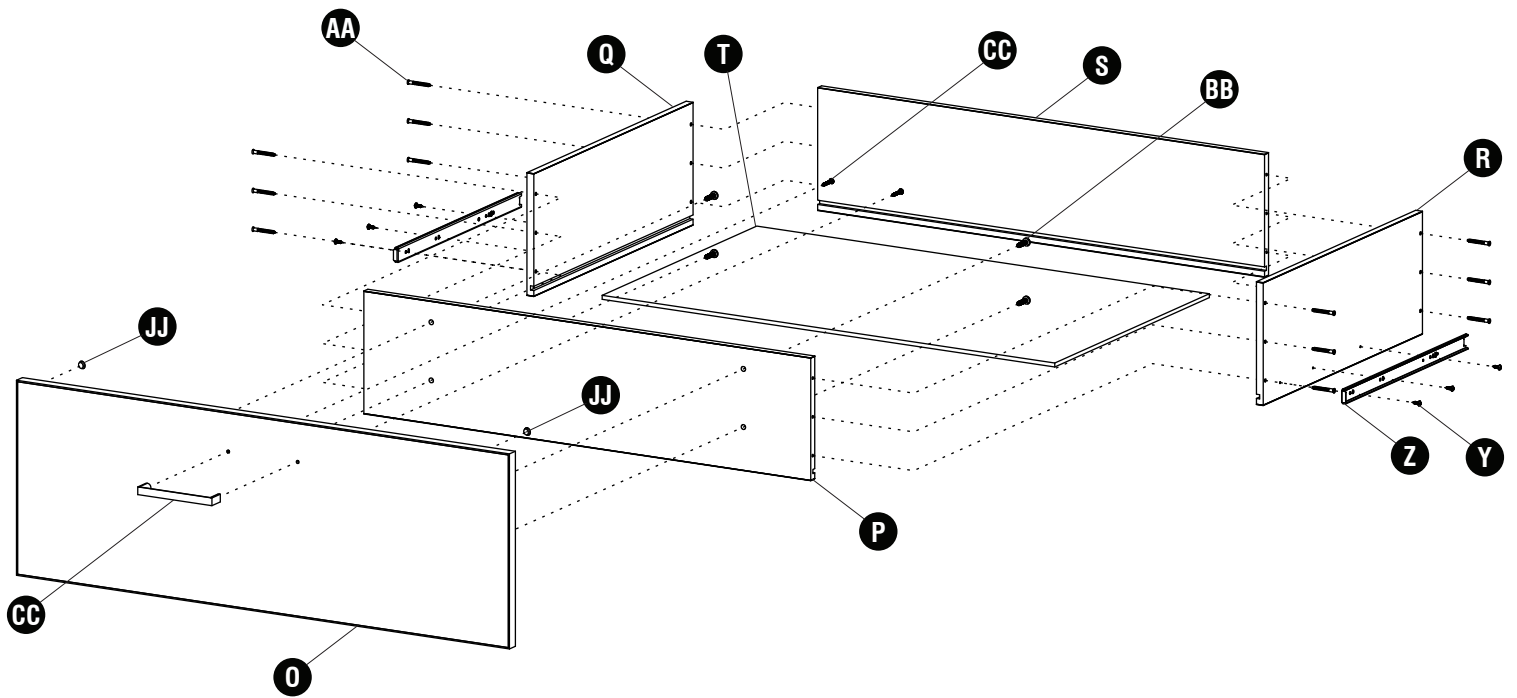
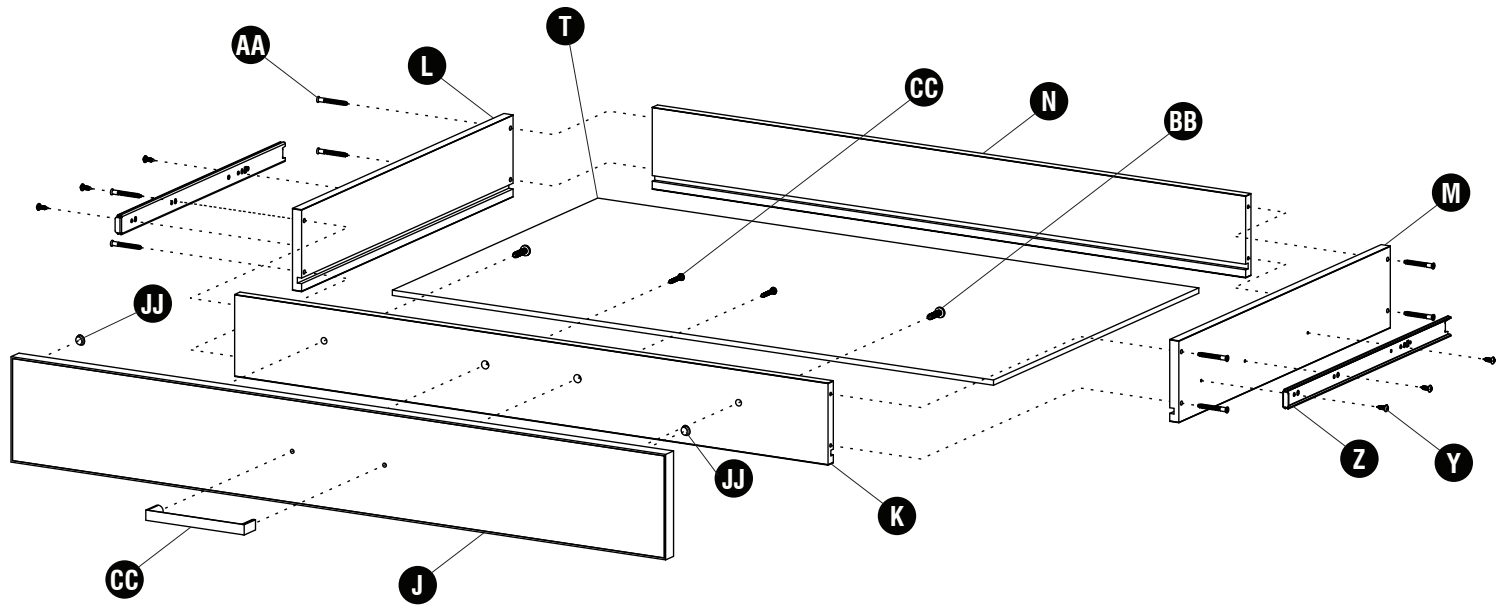

1 V (6)

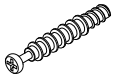

Unused holes.
Trous inutilisés.
Agujeros no utilizados.

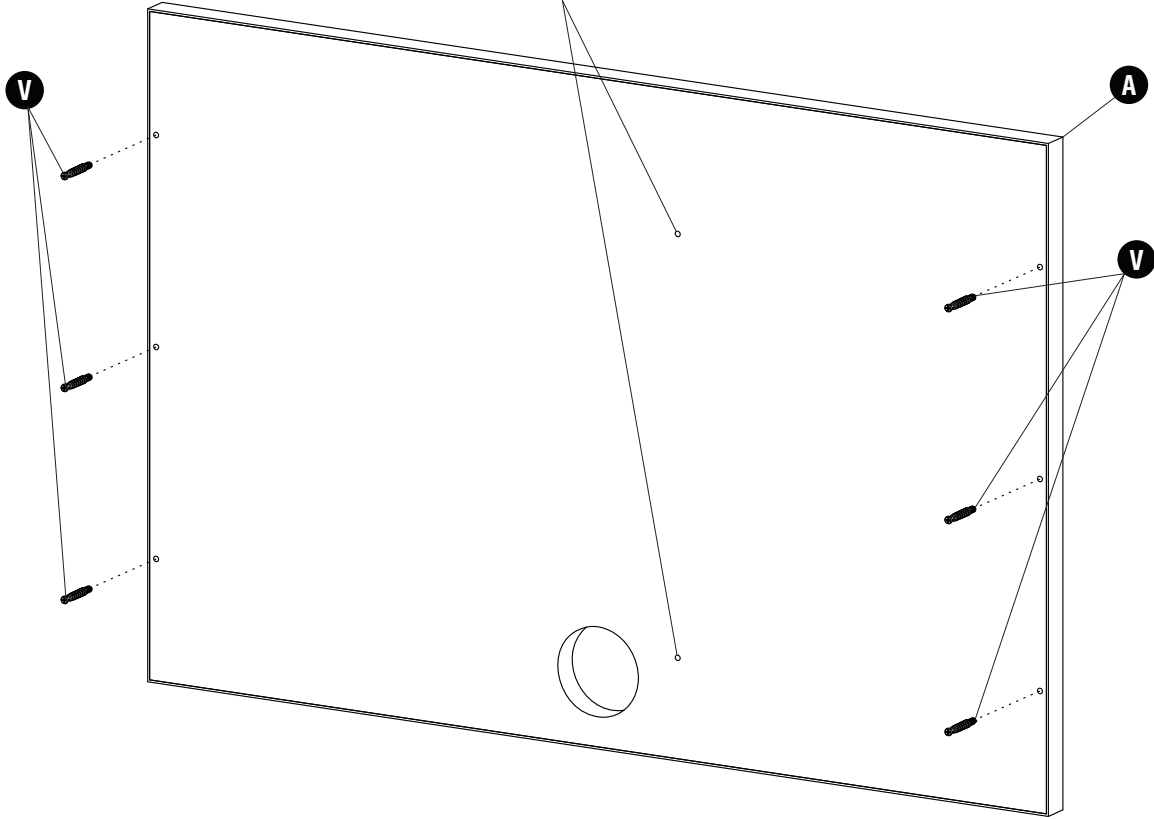

2 U W (6) (6)



W

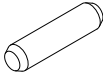

Unused holes.
Trous inutilisés.
Agujeros no utilizados.

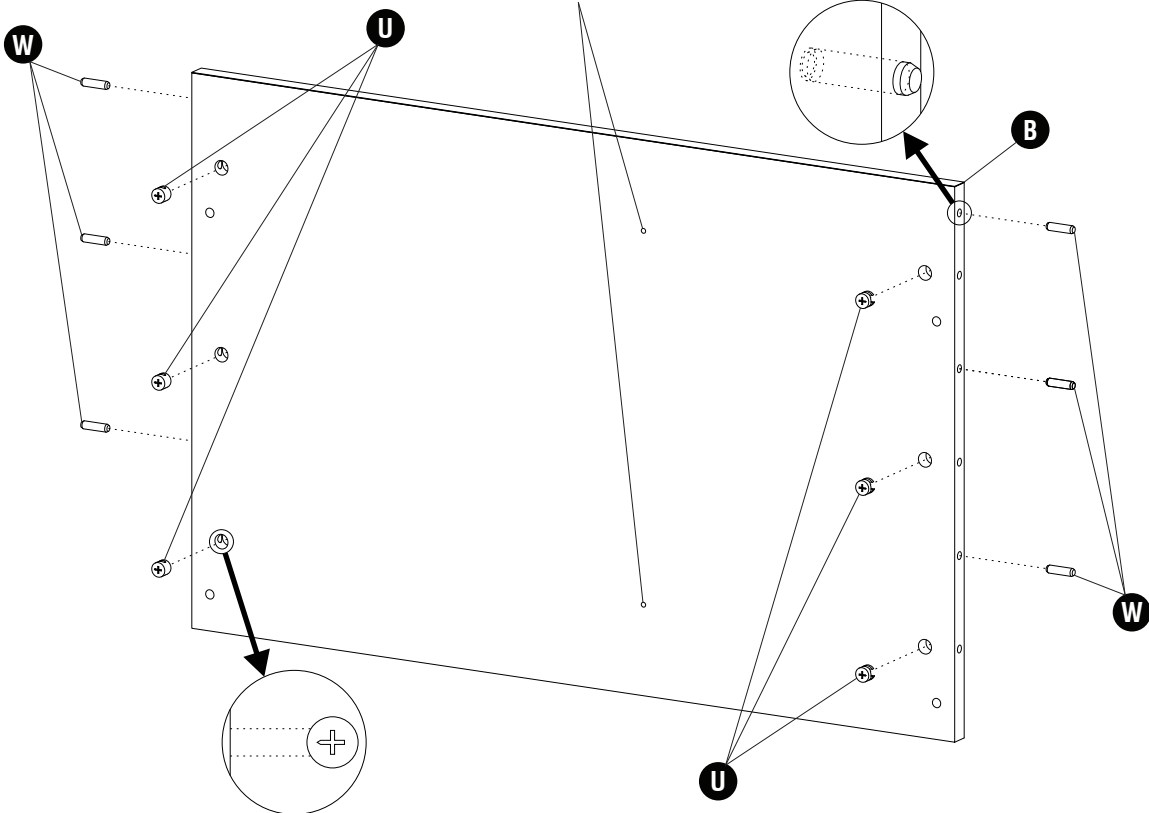

3 Z (3)

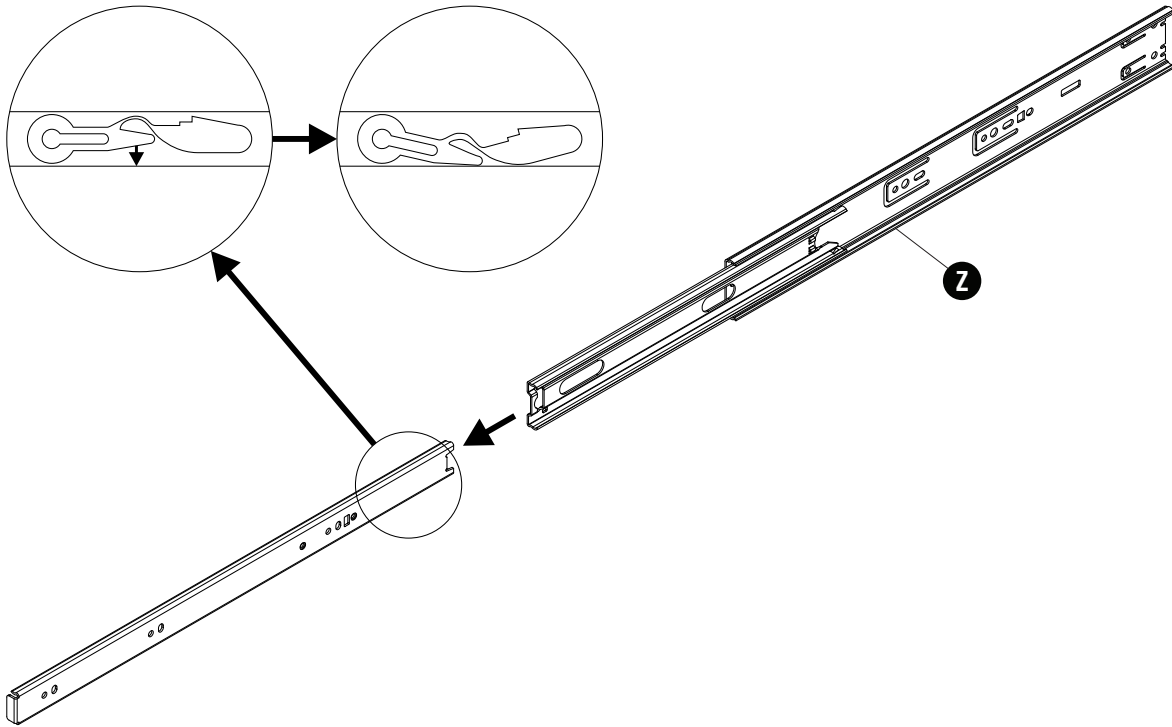

Remove front part of slide, and repeat for the other slides.

Retirez la partie avant de la diapositive et répétez l'opération pour l'autre diapositive.

Retire la parte frontal de la diapositiva y repita para la otra diapositiva.

4 U (6) V (12) W (4) X (4) Y (34) Z (3)

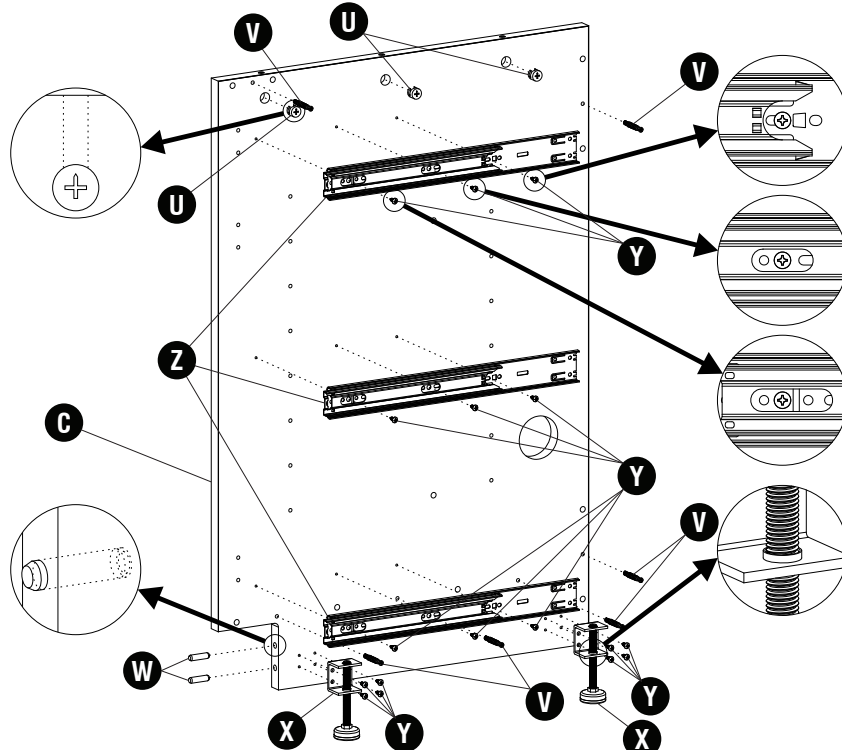

Install leveler bracket with the threads at the bottom. Repeat step for the right panel.

Installer le support de niveleur avec les filetages en bas. Répétez l'étape pour le panneau de droite.

Instale el soporte del nivelador con las roscas en la parte inferior. Repita el paso para el panel derecho.

5 U  (2) W  (4)

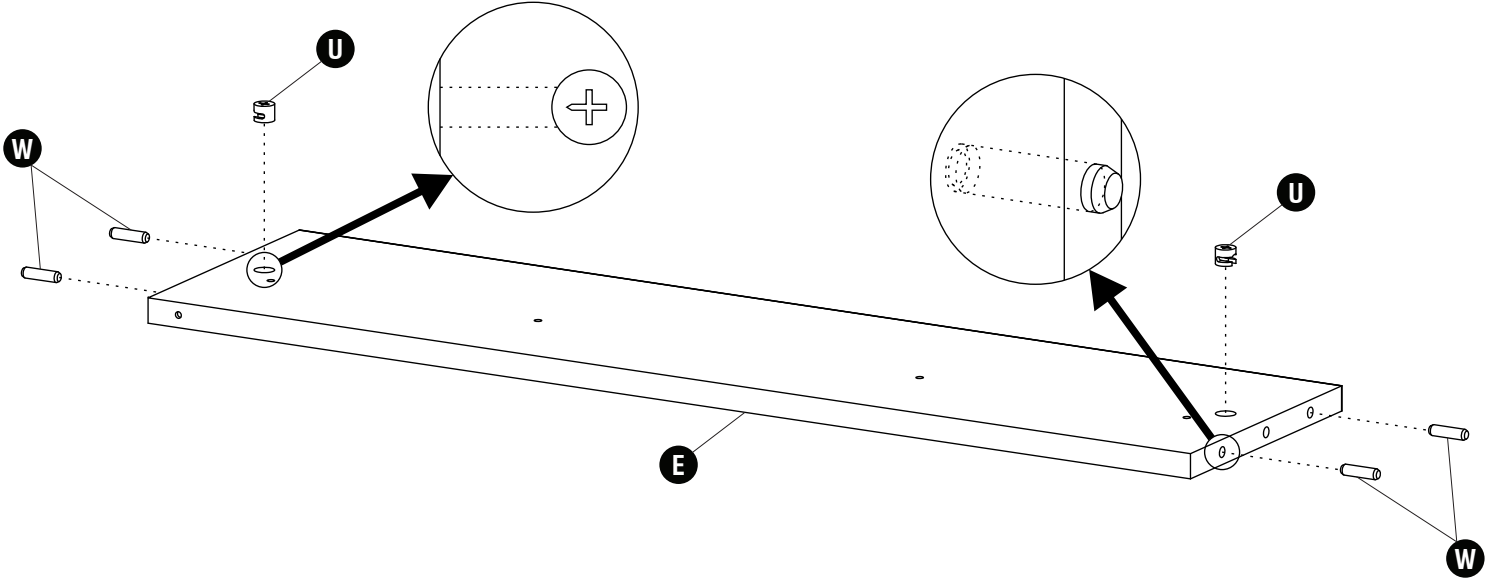

6 U  (2) W  (4)

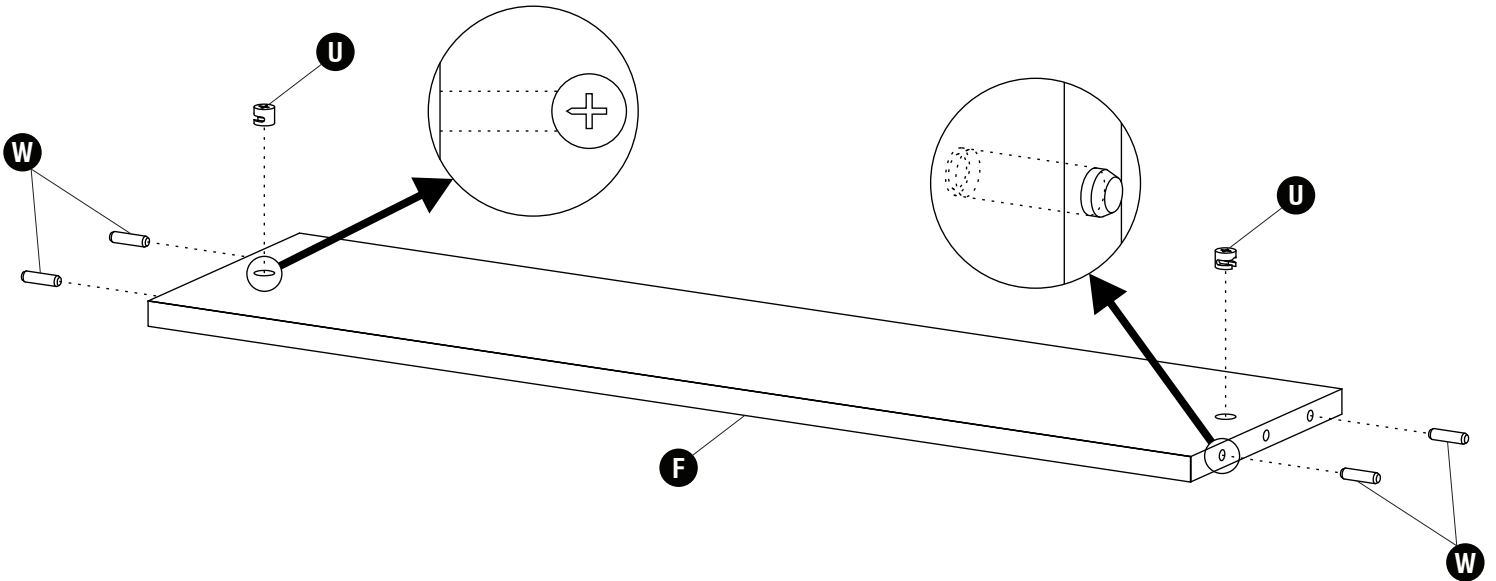

7 **U**  (2) **W**  (4)

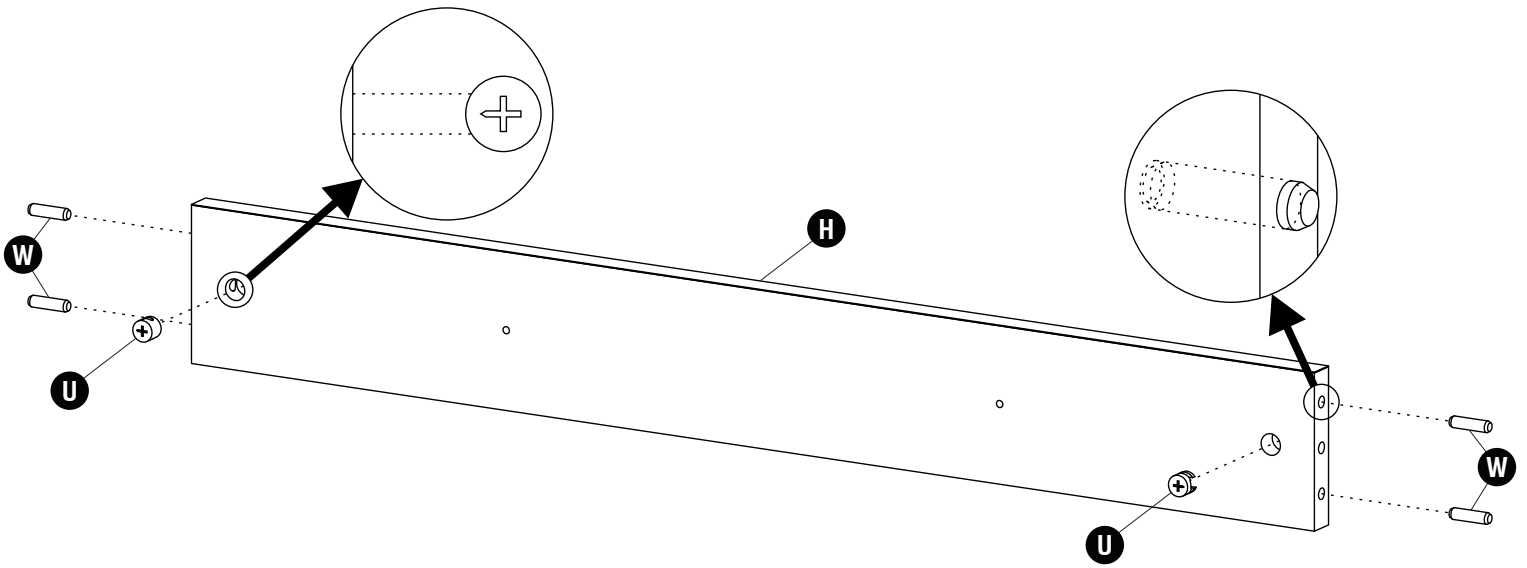

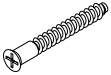
8 **AA**  (4)

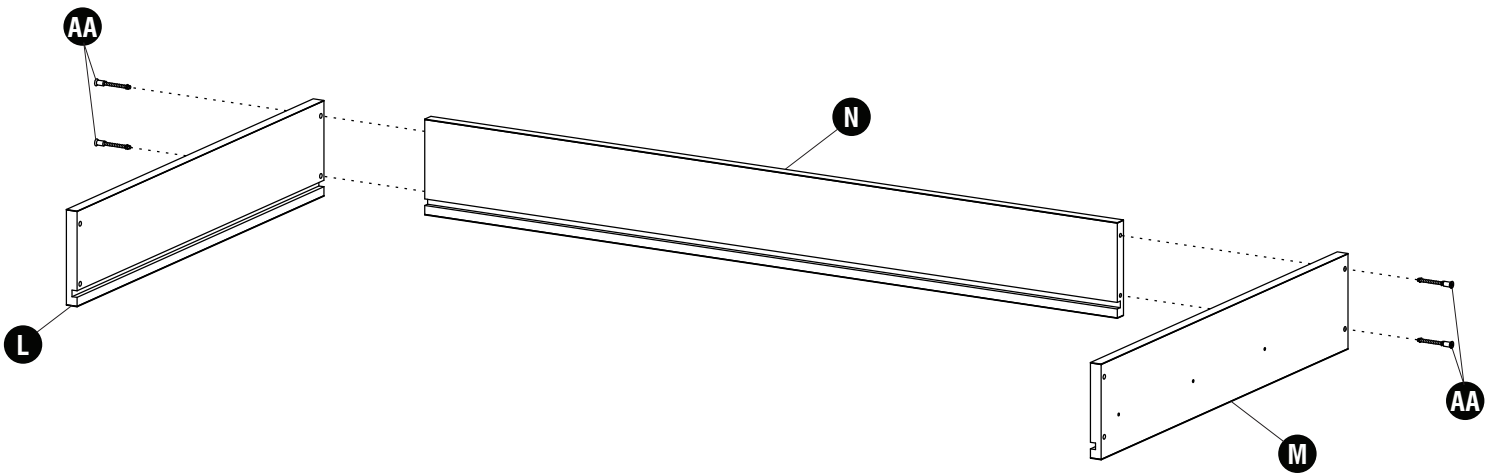

9 AA (4)

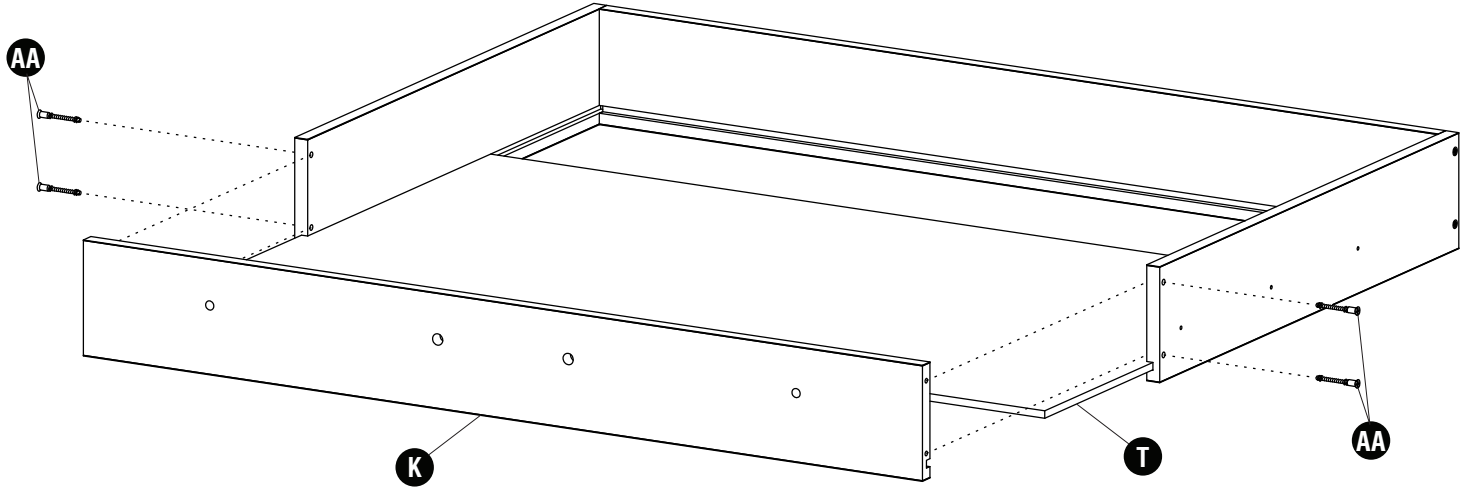
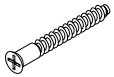

10 BB (2) CC (1) JJ (2)

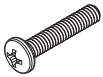

Short Screws (1").
Vis Courtes (1").
Tornillos Cortos (1").

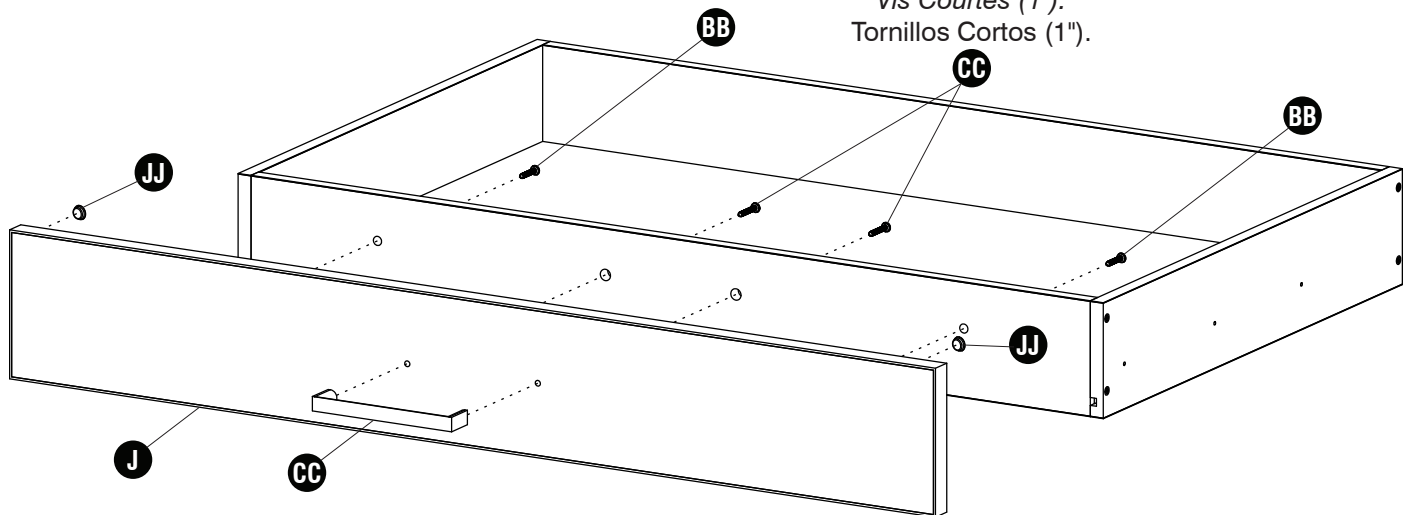

11 **Y** (6) **Z** (1)

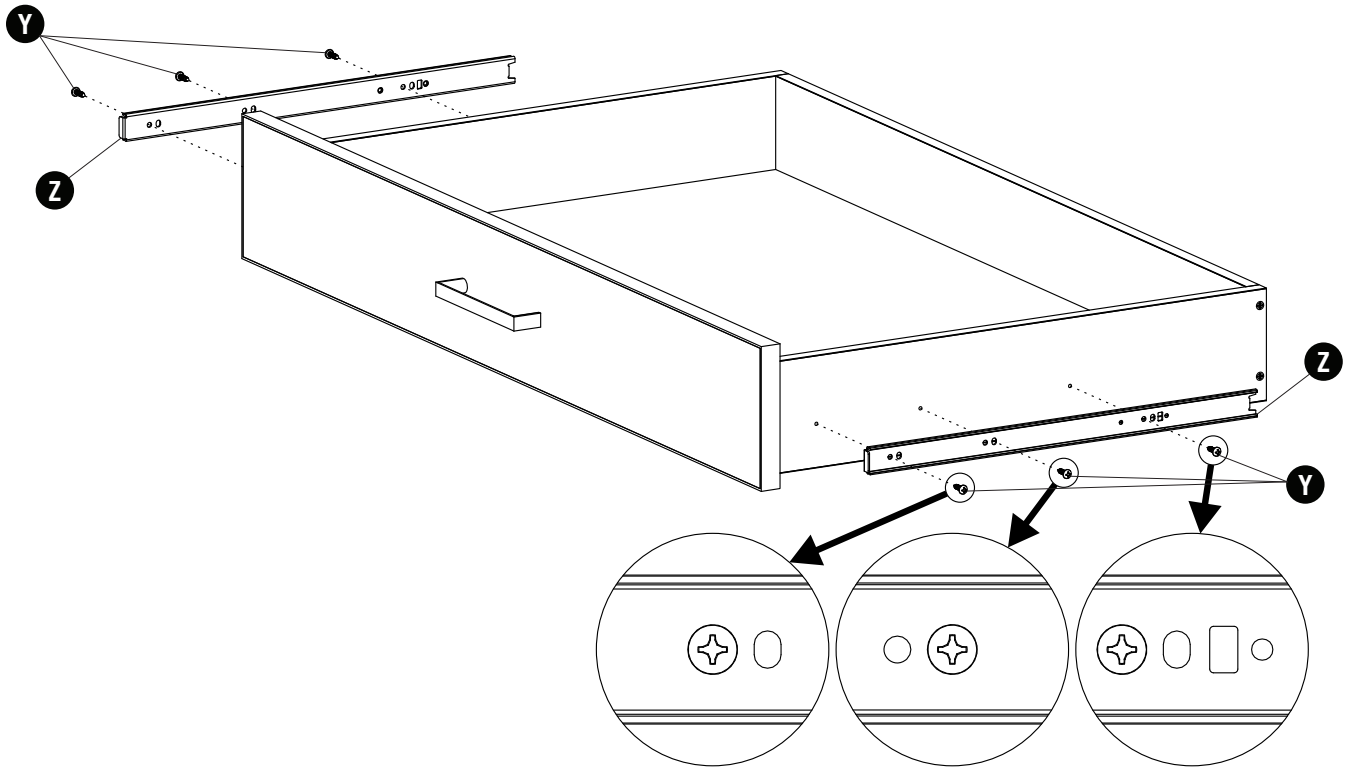

12 **AA** (6)

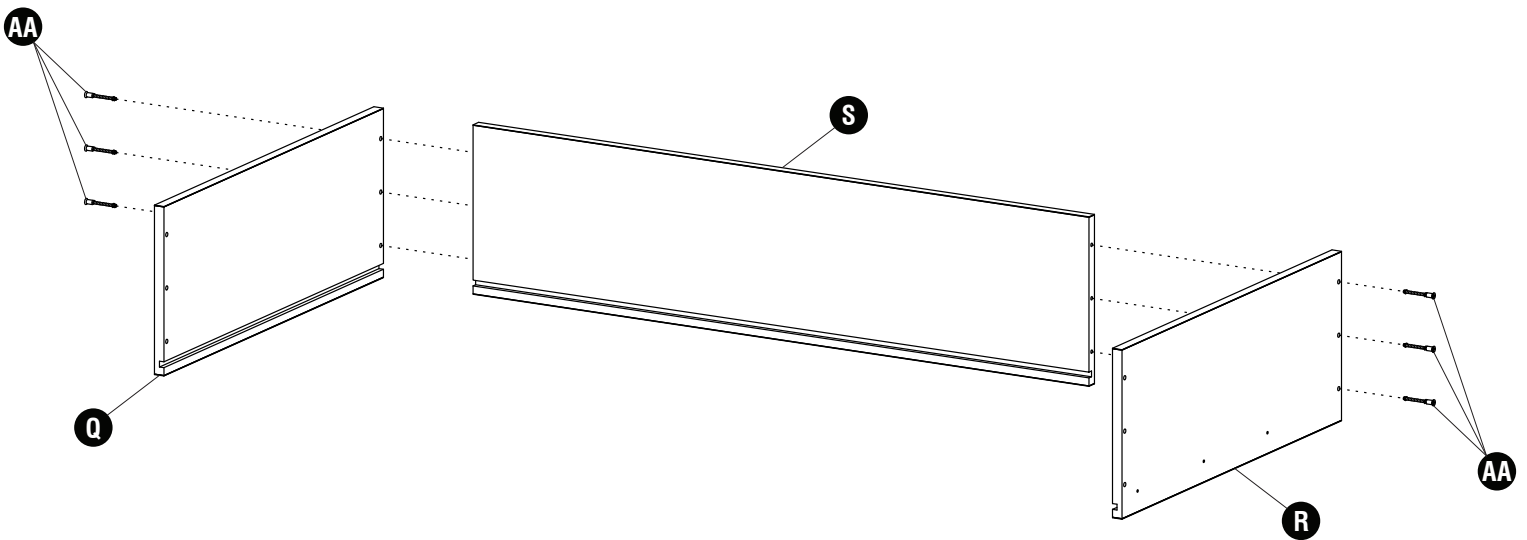

13 AA



(6)

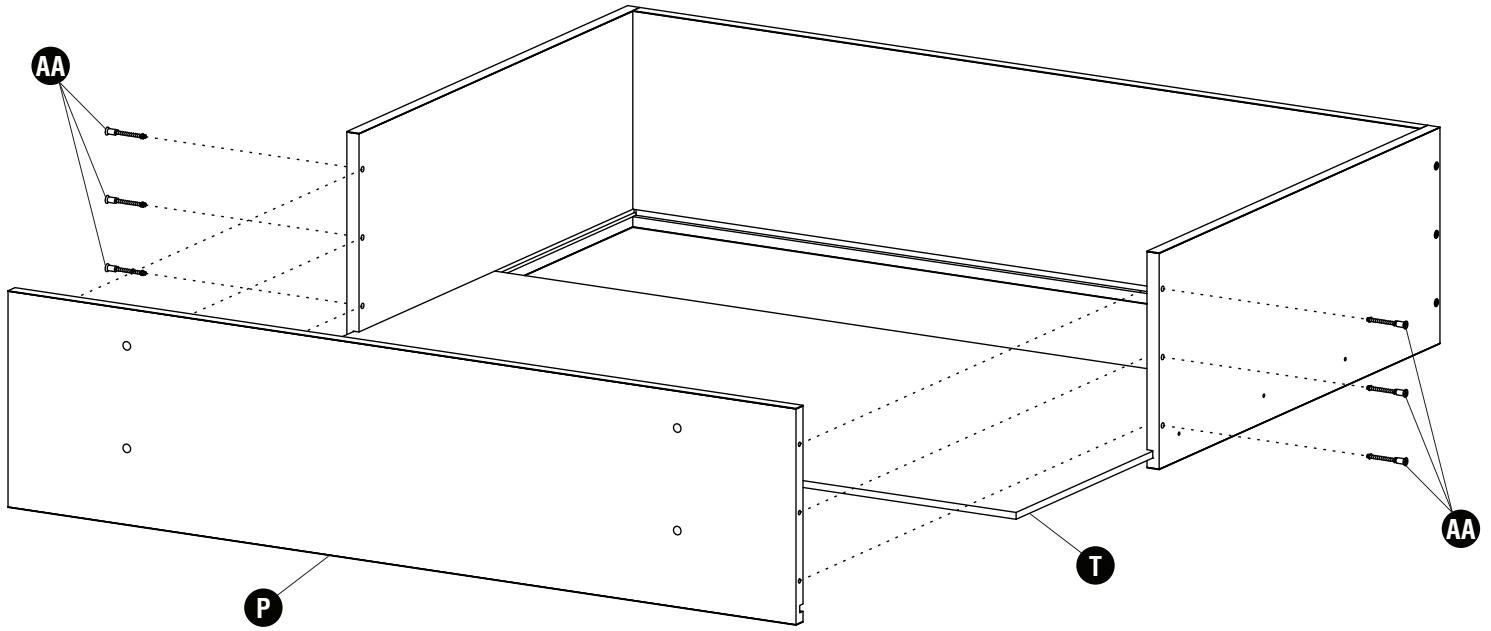

14 BB

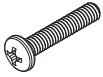

(4)

CC

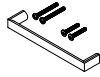

(1)

JJ



(2)

Short Screws (1").
Vis Courtes (1").
Tornillos Cortos (1").

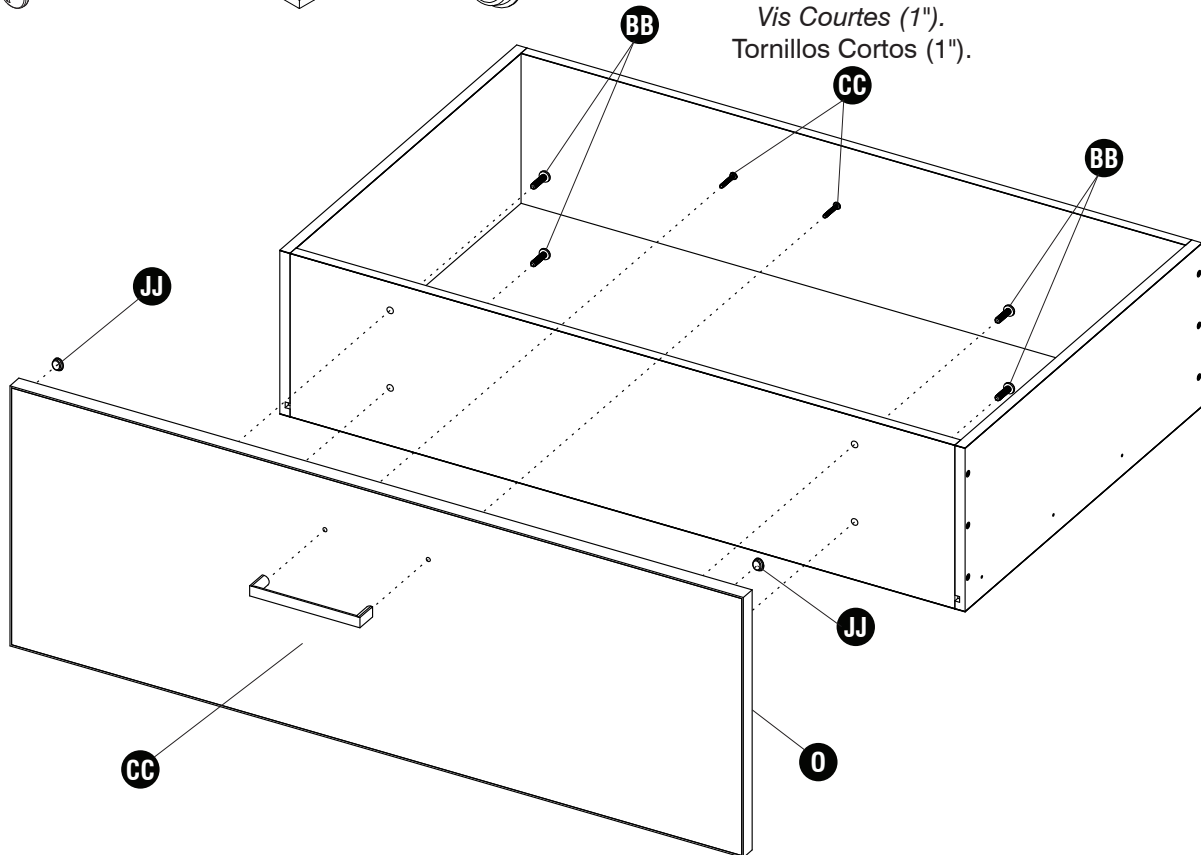

15 Y

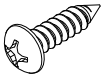

(6)

Z



(1)

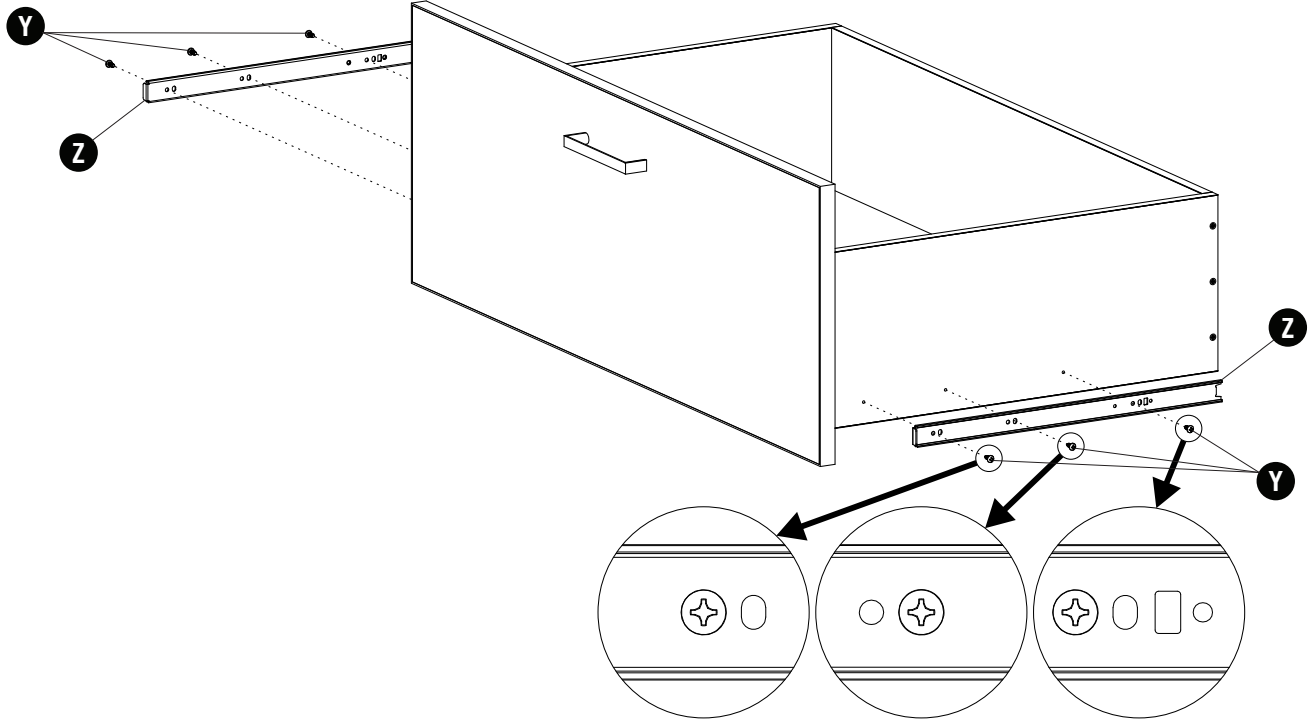

Repeat steps 12-15 for the other large drawer.
Répétez les étapes 12 à 15 pour l'autre grand tiroir.
Repita los pasos 12-15 para el otro cajón grande.

16

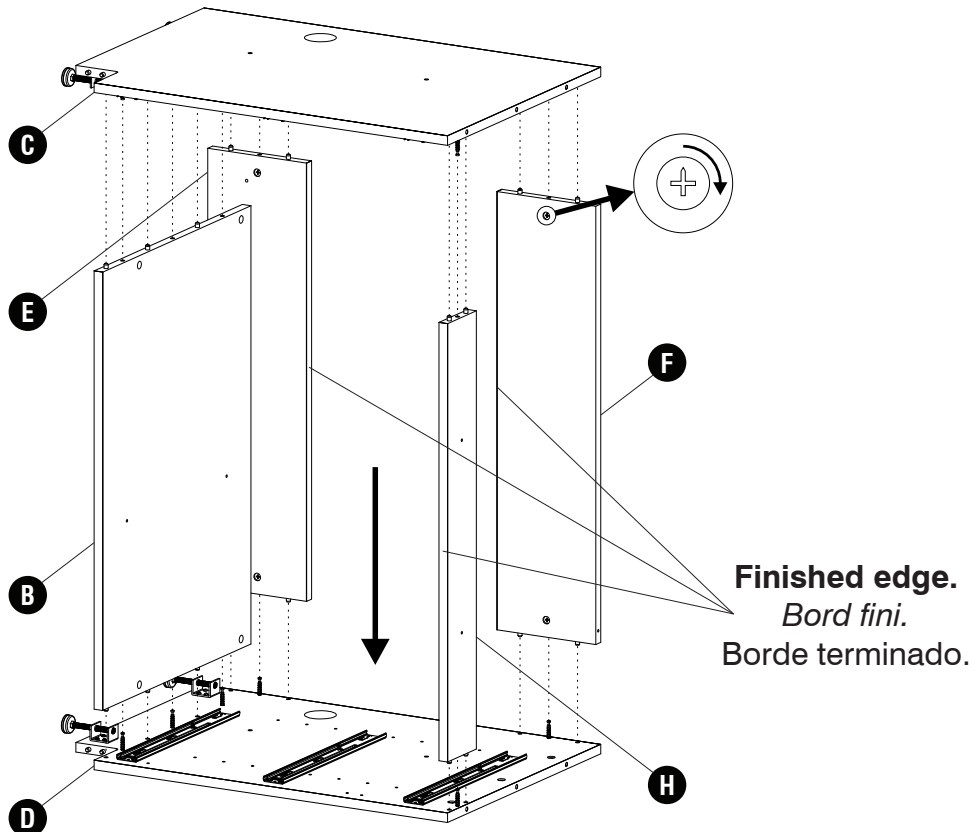

Be sure to tighten all the cams.
Assurez-vous de serrer toutes les cames.
Asegúrese de apretar todas las levas.

17

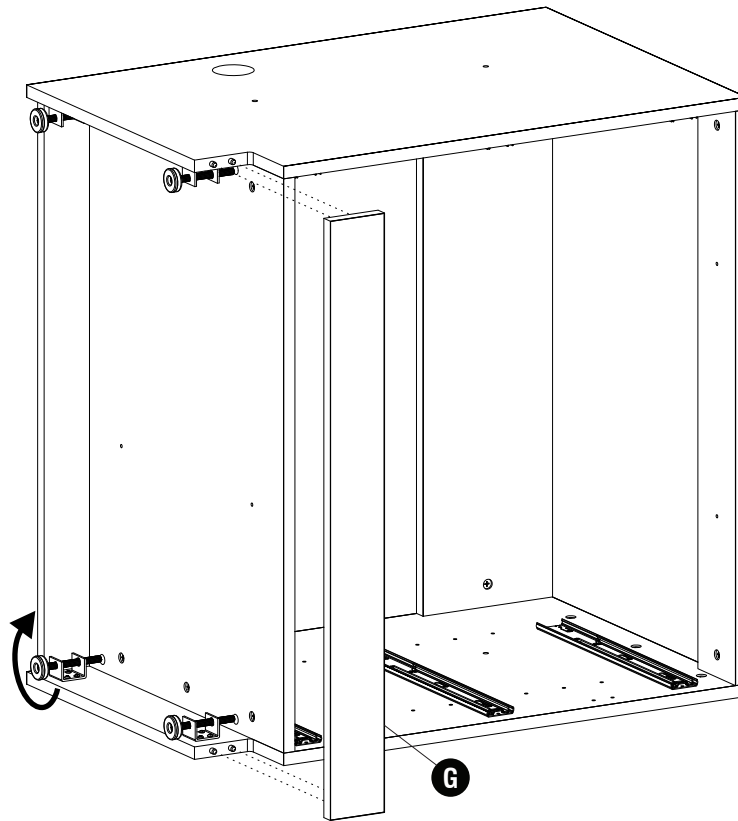

Screw in levelers all the way before turning assembly upright.

Visser complètement les niveleurs avant de remettre l'assemblage à la verticale.

Atornille los niveladores completamente antes de colocar el conjunto en posición vertical.

18 DD (2)

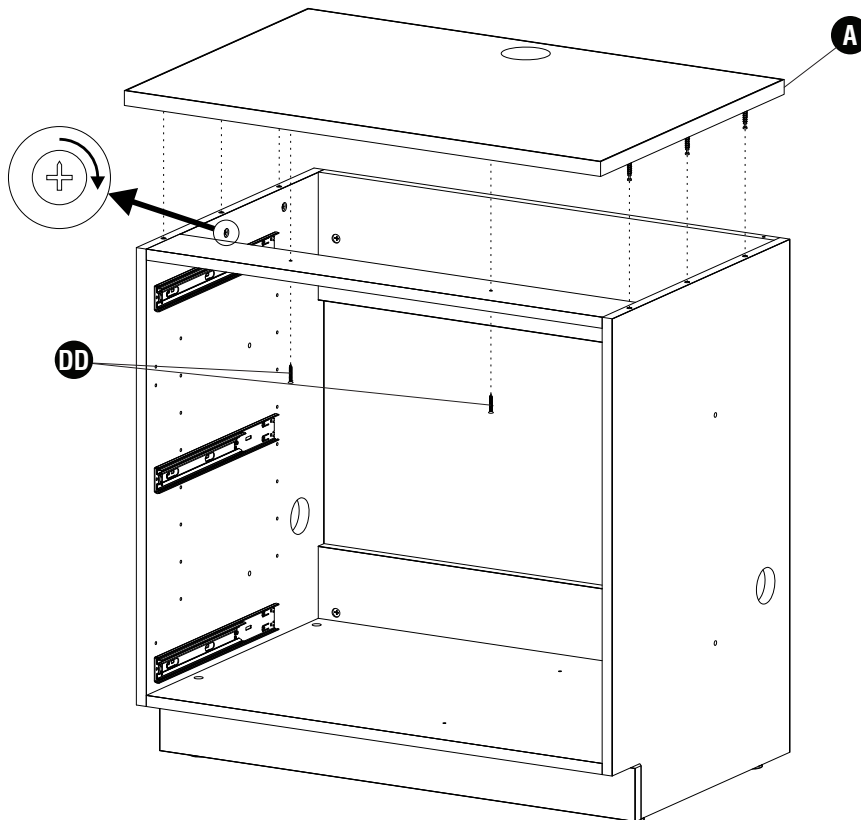

Be sure to tighten all the cams.

Assurez-vous de serrer toutes les comes.

Asegúrese de apretar todas las levas.

19 AA

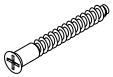

(8)

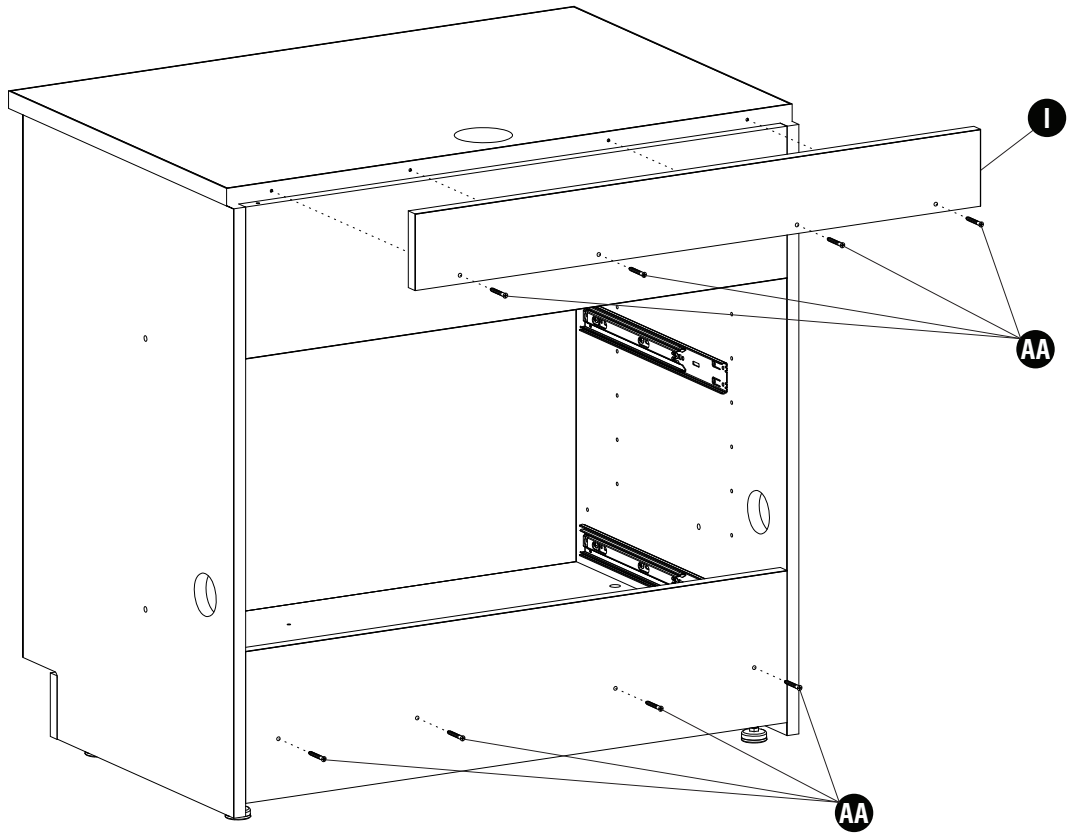

20

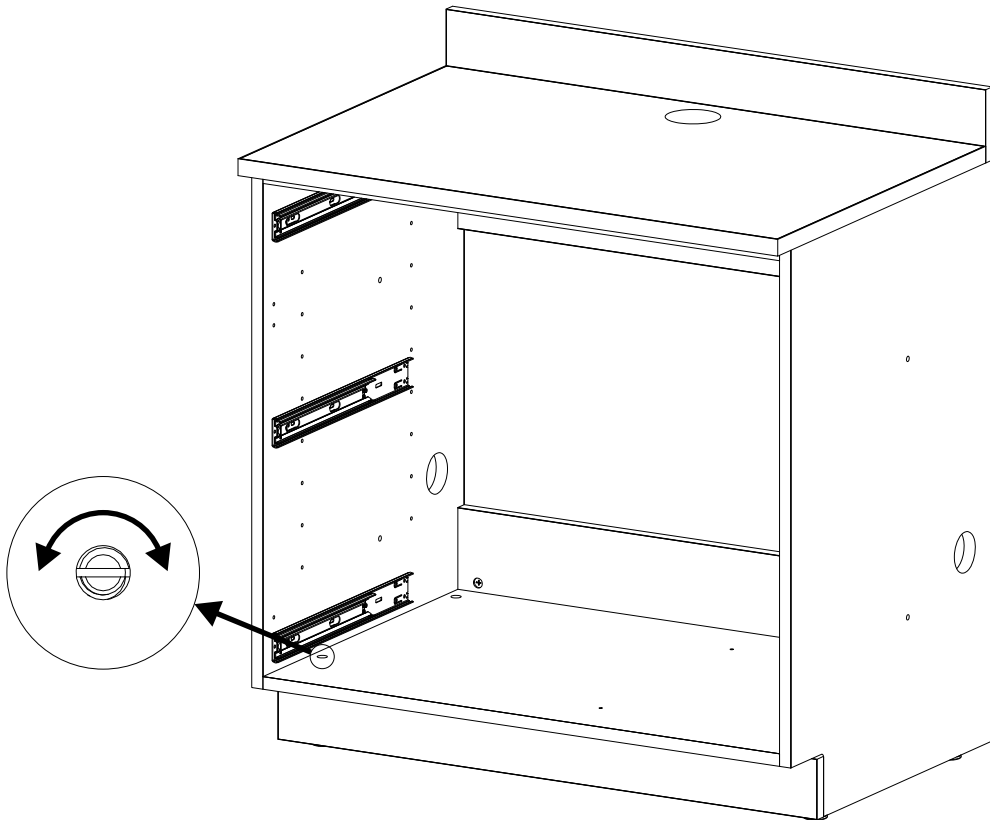

Use a flathead screwdriver to adjust leveler height and to level the cabinet.

Utiliser un tournevis à tête plate pour régler la hauteur du niveleur et pour niveler l'armoire.

Use un destornillador de punta plana para ajustar la altura del nivelador y nivelar el gabinete.

21

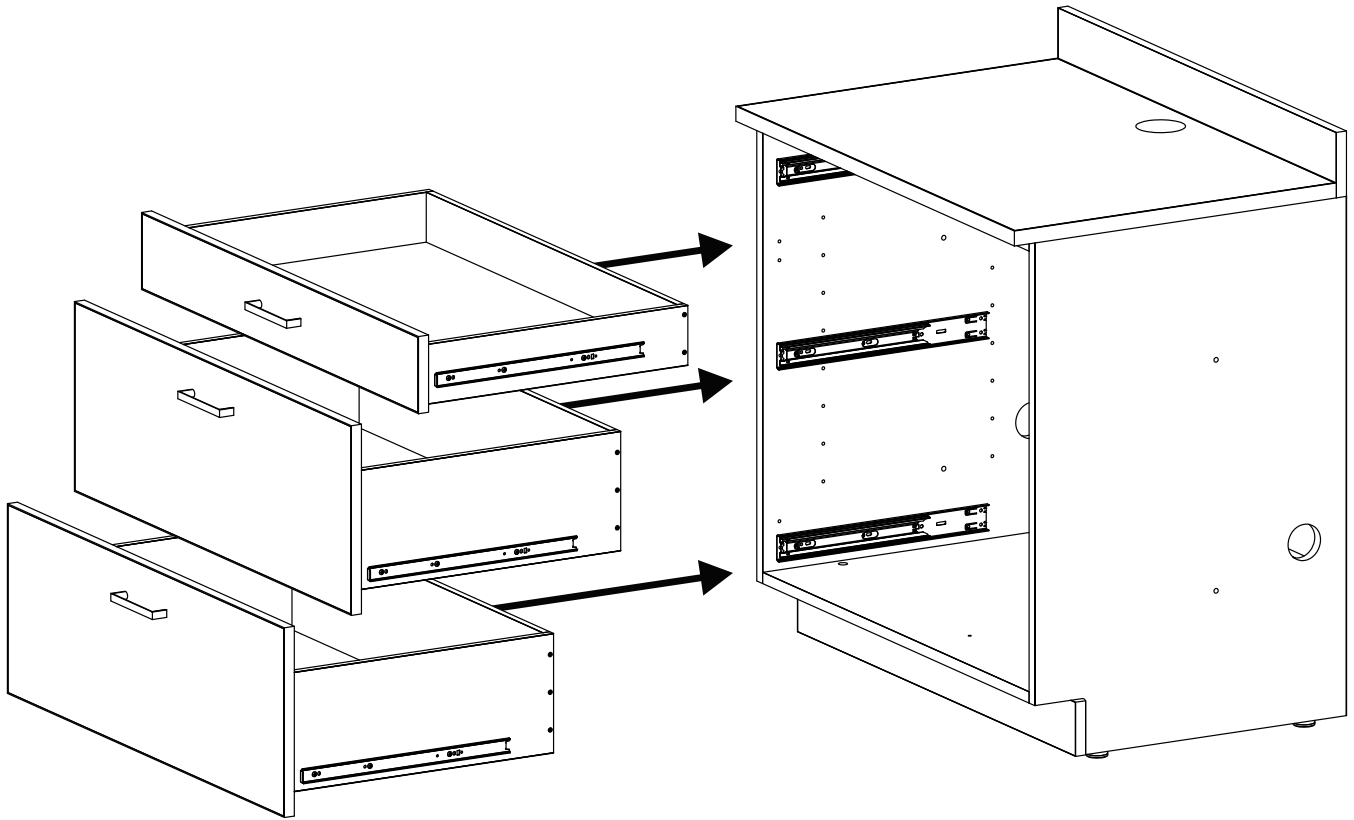

22

- EE (1) FF (2) GG (4)

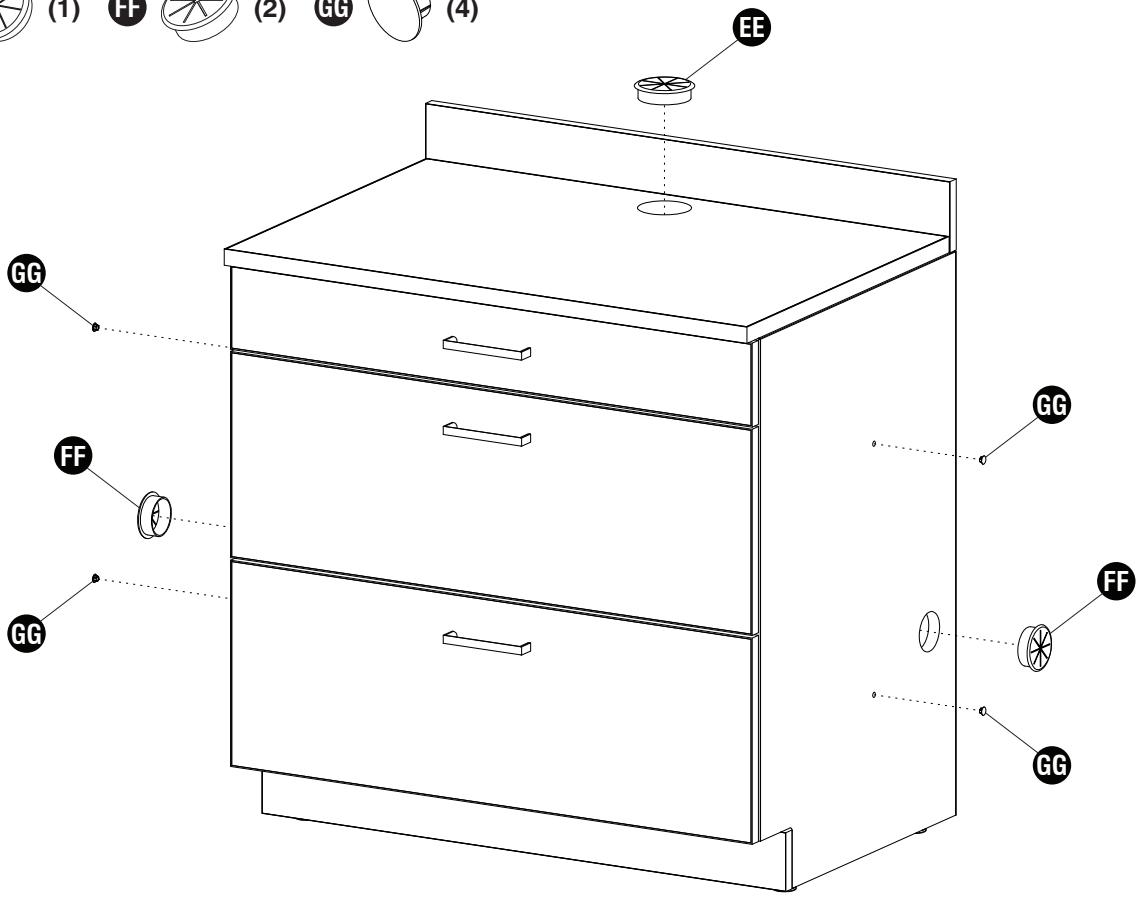

23 EE (2) FF (4) GG (4) HH (2) II (2)

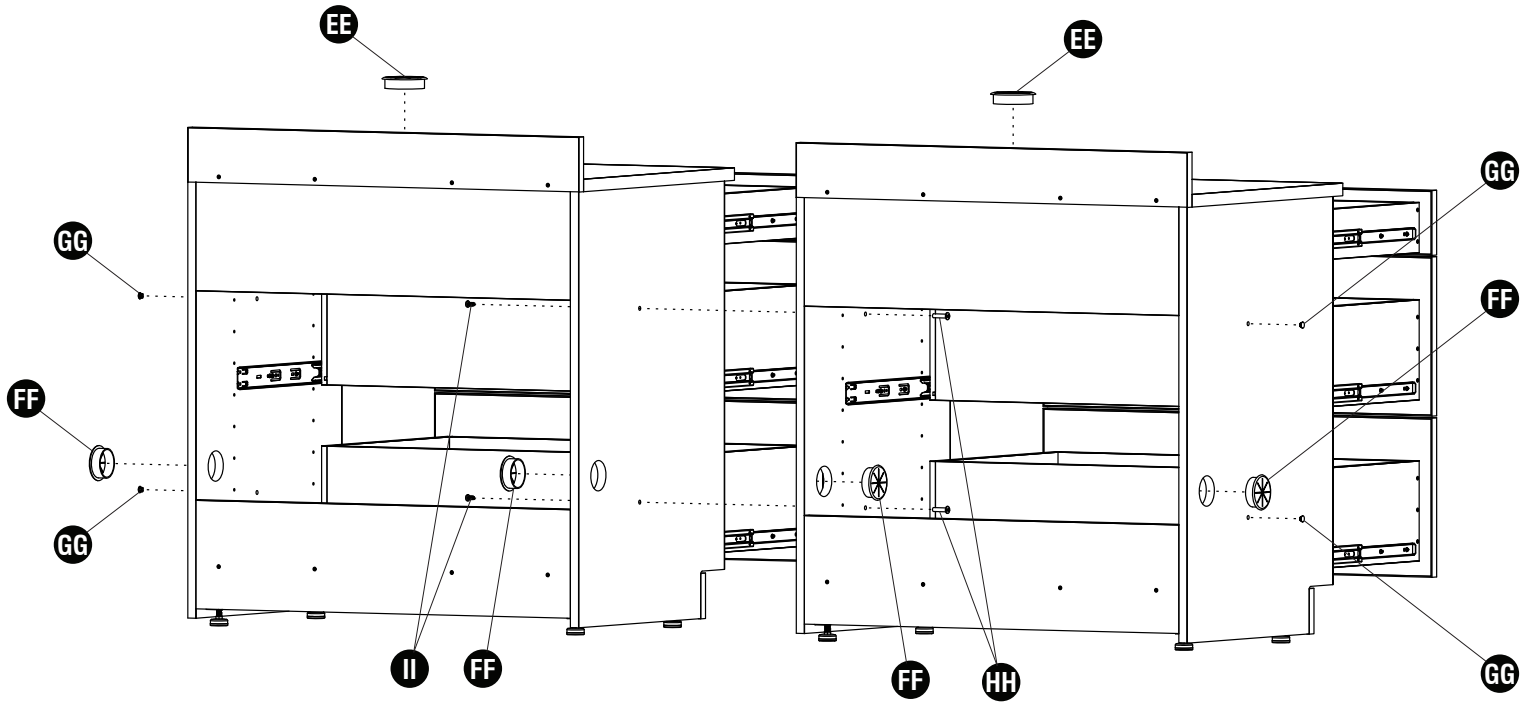

Step only for ganging multiple cabinets together.
Étape uniquement pour regrouper plusieurs armoires.
Paso solo para agrupar varios gabinetes juntos.